



HEPHA TECH

火神科技

<Q/OCNW 001-2020>

# *Product Specification of Gasification Treatment Equipment HP031 for Solid Waste*

Hephaestus (Guangdong Province) Environmental Technology Co., Ltd

## Revision History

Version	Date	Description	Author
<v1.0>	<2021-8-10>	Initial Draft of Integrated Pyrolysis Gasifier Specifications	Qingping Chen
<v1.1>	<2022-5-22>	Specification Revision for HP031	Yu Cheng
<v1.2>	<2023-2-17>	Modification of Special Terms and Annotations	Qingping Chen
<v1.3>	<2024-5-12>	Parameters Update	Yu Cheng

**CATALOG**

<b>1. OVERVIEW</b> .....	<b>5</b>
1.1 PRODUCT INTRODUCTION .....	5
1.2 PERFORMANCE INDICATORS .....	5
<b>2. REFERENCES, TERMINOLOGY, AND DEFINITIONS</b> .....	<b>6</b>
2.1 REFERENCED DOCUMENTS.....	6
2.2 TERMINOLOGY AND DEFINITIONS.....	7
2.2.1 TREATMENT TECHNOLOGY OF SOLID WASTE .....	7
2.2.2 STRAW GASIFICATION FURNACE.....	7
2.2.3 TRANSPORTATION .....	7
2.2.4 TREATMENT.....	7
2.2.5 NONINFECTIOUS WASTE .....	7
2.2.6 INFECTIOUS WASTE.....	7
2.2.7 BIOMASS GASIFIER .....	8
2.2.8 RATED GAS PRODUCTION .....	8
<b>3. PRODUCT DESCRIPTION</b> .....	<b>8</b>
3.1 STRUCTURE AND FUNCTION.....	8
3.2 WORKING PRINCIPLE .....	8
3.3 EQUIPMENT MODELS .....	9
3.3.1 <i>Horizontal Gasification Incinerator Φ1100-L1800-h2300</i> .....	10
3.3.2 <i>Horizontal Gasification Incinerator Φ1200-L2700-h2600</i> .....	10
3.3.3 <i>Vertical Rectangular Gasification Incinerator HP031</i> .....	11
3.4 MANUFACTURING .....	12
3.4.1 <i>Material Specifications</i> .....	12
3.4.2 <i>Processing and Welding Techniques</i> .....	13
3.5 COMPONENTS .....	13
3.5.1 <i>Feeding System</i> .....	13
3.5.2 <i>Furnace Body</i> .....	13
3.5.3 <i>Grate</i> .....	13
<b>4. INSPECTION AND TESTING METHODS</b> .....	<b>14</b>
4.1 VISUAL INSPECTION.....	14
4.2 AIRTIGHTNESS TESTING .....	14
4.3 PERFORMANCE AND GAS INDICATORS TESTING.....	14
<b>5. WASTE GASIFICATION PROCESS</b> .....	<b>14</b>
5.1 SOLID WASTE TREATMENT PROCESS .....	14
5.2 OPERATIONAL INDICATORS.....	15
5.3 EXHAUST EMISSION STANDARDS .....	15
<b>6. INSPECTION RULES</b> .....	<b>16</b>
6.1 CLASSIFICATION OF INSPECTIONS .....	16

6.2	FACTORY INSPECTION .....	16
6.3	TYPE INSPECTION .....	17
6.4	SAMPLING METHODS .....	17
6.5	INSPECTION ITEMS AND METHODS.....	17
<b>7.</b>	<b>MARKING, DOCUMENTATION, AND TRANSPORTATION .....</b>	<b>18</b>
7.1	LABELING .....	18
7.2	DOCUMENTATION .....	18
7.3	STORAGE AND TRANSPORTATION.....	18
<b>8.</b>	<b>WARRANTY PERIOD.....</b>	<b>18</b>

## 1. Overview

### 1.1 Product Introduction

HP031 is a solid waste gasification and incineration treatment device developed and manufactured by **Hephaestus (Guangdong) Environmental Technology Co., Ltd.** This equipment is widely applicable for the on-site, immediate, and harmless gasification and pyrolysis treatment of municipal solid waste, agricultural and forestry wood waste, kitchen waste, organic construction and renovation waste, as well as industrial organic waste, medical waste, animal organic matter, and certain hazardous wastes. Additionally, it facilitates resource utilization. This document provides detailed information on the relevant technical specifications, testing, and usage methods of the HP031. It also introduces processes such as solid waste storage, feeding, gasification treatment, secondary combustion of gas, flue gas treatment, waste residue stabilization, and resource utilization.

**Note 1:** Solid waste gasification and incineration treatment refers to the removal of organic components and is categorized into two main types:

- **Ordinary Waste:** Includes municipal solid waste; agricultural and forestry wood waste, such as agricultural residues (e.g., straw), forestry waste (e.g., bamboo and wood waste, reeds, and other grass-like waste), and wood processing waste; kitchen waste (dewatered and subjected to simple solid-liquid separation); organic waste from construction templates and renovations; etc.
- **Special Waste:** Includes industrial organic waste (a wide variety of waste generated during production and processing in industrial parks or factories); medical waste (including pharmaceutical waste); animal organic matter (e.g., carcasses of diseased livestock and poultry, slaughterhouse waste); hazardous waste (organic waste and toxic or hazardous wastewater listed in the national hazardous waste catalog); etc.

**Note 2:** Resource utilization refers to the energy recovery from waste (e.g., through supporting boilers, hot air systems, or power generation); production of carbon-based materials (e.g., charcoal for energy use, semi-carbonized materials for organic fertilizers); production of activated carbon; and recovery of metals combined with processes to remove organic components.

### 1.2 Performance Indicators

- **Moisture content:**  $\leq 80\%$
- **Residue rate:**  $\leq 5\%$
- **Proportion of inorganic substances in ash residue:**  $\geq 98\%$
- **Gasification efficiency:**  $\geq 70\%$
- **Calorific value of combustible gas:**  $\geq 4600 \text{ KJ/Nm}^3$
- **Hydrogen gasification rate ( $\text{H}_2$ ):**  $\geq 4\%$

- **Particulate matter:**  $\leq 100 \text{ mg/Nm}^3$
- **Carbon monoxide gasification rate (CO):**  $\geq 25\%$
- **Hydrogen sulfide (H<sub>2</sub>S):**  $\leq 20 \text{ mg/Nm}^3$
- **Service life:**  $\geq 15$  years
- **Noise level:**  $\leq 75 \text{ dB}$

Note: Solid waste moisture content should be  $\leq 40\%$ , referring to the average moisture content of waste entering the furnace. The waste only requires dewatering before entering the furnace, with no need for dehydration or drying. Even if the moisture content reaches 70%, wet waste can be directly gasified and incinerated through special processes, such as mixing with dry waste.

## 2. References, Terminology, and Definitions

### 2.1 Referenced Documents

The following documents are essential for the application of this document. For dated references, only the cited edition applies. For undated references, the latest edition (including any amendments) applies.

- **GB 713-2014:** Steel plates for boilers and pressure vessels
- **GB/T 985.1-2008:** Recommended weld preparation for gas welding, arc welding, gas-shielded welding, and high-energy beam welding
- **GB/T 3274-2017:** Hot-rolled steel sheets and strips of carbon structural steels and low-alloy structural steels
- **GB/T 5117-2012:** Welding rods for non-alloy and fine-grain steels
- **GB/T 8163:** Seamless steel pipes for conveying fluids
- **GB/T 9437-2009:** Heat-resistant cast iron
- **GB/T 12208-2008:** Methods for determining artificial gas components and impurities
- **GB 50211-2014:** Code for construction and acceptance of industrial furnace masonry
- **DLT 869-2018:** Welding technology code for thermal power plants
- **DL/T 902-2004:** Technical conditions and inspection methods for wear-resistant refractory materials
- **HJ/T 177-2017:** Technical specifications for centralized incineration of medical waste
- **JB/T 5000:** General technical conditions for heavy machinery
- **NY/T 433-2014:** Green food plant-based protein beverages
- **NY/T 1017-2006:** Testing methods for straw gasification equipment and systems

- **NYT 1417-2007**: Quality technical specifications for straw pyrolysis gasification furnaces
- **GB 18485-2014**: Standard for pollution control in municipal solid waste incineration
- **NYT 2907-2016**: Technical conditions for atmospheric fixed-bed biomass gasifiers
- **GB/T 51435-2021**: Technical standards for rural solid waste collection and treatment

## 2.2 Terminology and Definitions

### 2.2.1 Treatment technology of solid waste

A high-temperature treatment system for solid waste, in which waste is gasified in a gasification furnace to produce residues and combustible gases. Residues are stabilized for use as construction materials or for storage and landfill, while gases are burned in specialized gas stoves to produce flue gas, which is either discharged directly into the atmosphere or treated for emission.

### 2.2.2 Straw gasification furnace

A device for treating solid waste, primarily comprising a pyrolysis gasification furnace body (providing stable reaction conditions for agricultural waste), gas pipelines, gas stoves, and flue gas purification systems.

### 2.2.3 Transportation

Refers to the process in which specific vehicles transport polluting waste (e.g., medical waste) directly from its source to disposal facilities in compliance with this standard.

### 2.2.4 Treatment

The process in which solid waste treatment units apply specified technical measures to make waste harmless, reduce its volume, and enable resource utilization. This involves altering the biological characteristics and composition of the waste to eliminate its potential infectious hazards using various methods, techniques, and processes.

### 2.2.5 Noninfectious waste

Includes materials such as wastepaper, used pallets (wood chips), bandages, gauze, cotton wadding (fibrous debris); acid and alkaline waste liquids from X-ray film processing, formalin, and blood testing; glass or ceramics from ampoules and laboratory equipment; plastics from syringes, X-ray films, and sterilized injection needles; rubber from gloves processed after natural rubber use; expired drugs (e.g., tablets, antibiotics, ointments, and vaccines).

### 2.2.6 Infectious waste

Includes waste generated by hospital patients (e.g., contaminated domestic waste),

post-surgery pathological waste (e.g., organs, tissues), experimental waste from pathogens (e.g., culture mediums, lab animals), blood-contaminated waste, sharps contaminated with blood (e.g., syringes, scalpels), and clinical waste (e.g., surgical packs, dressing gauze, catheterization kits, maternity packs).

### 2.2.7 Biomass Gasifier

A device that gasifies biomass into combustible gases. Biomass serves as the raw material, and air or steam acts as the gasification agent, enabling oxidation and reduction reactions (collectively termed gasification reactions). It primarily consists of the furnace body, hearth, grate, feeding system, ash discharge system, and auxiliary equipment.

### 2.2.8 Rated gas production

Refers to the quantity of combustible gas produced by a gasifier per unit of time under normal operating conditions.

## 3. Product Description

### 3.1 Structure and Function

The integrated solid waste gasification and pyrolysis treatment equipment consists of two main parts: the gasification furnace and the gas stove, as shown in Figure 1. The gasification furnace serves as the critical core equipment for solid waste gasification treatment.

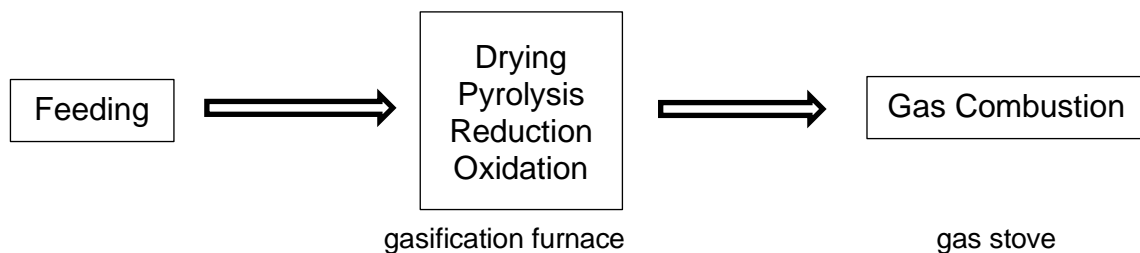

Figure 1: Structural Schematic of Solid Waste Gasification and Pyrolysis Treatment Equipment

- **Gasification Furnace:** Responsible for feeding, gasification (drying, pyrolysis, reduction, and oxidation), and ash discharge.
- **Gas Stove:** Fully burns the mixed gases (including carbon monoxide, hydrogen, and methane) produced by the gasification furnace.

### 3.2 Working Principle

Solid waste mixed with auxiliary gasification materials enters the upper storage chamber of the furnace and is fed into the gasification furnace under gravity. The material is evenly distributed inside the furnace, which is divided from top to bottom into the drying layer, pyrolysis layer, reduction layer, and oxidation layer.

During operation:

1. A controlled amount of air is introduced from the bottom of the furnace to support oxidation in the oxidation layer.
2. The waste combustion temperature rises to 900–1600°C, generating flue gas containing carbon dioxide.
3. The heat generated by the flue gas is transferred to the reduction layer, where the temperature is maintained at 700–900°C, reducing carbon dioxide into carbon monoxide, hydrogen, and methane gases.
4. Residual heat continues upward into the pyrolysis layer, thermally decomposing and carbonizing the waste to produce combustible gases primarily composed of hydrogen, carbon monoxide, and methane, along with various alkanes and aromatic hydrocarbons. This mixture is referred to as mixed gas.

The mixed gas enters the gas stove through a pipeline for secondary combustion. The gas stove, approximately 1.0m in height, is designed to ensure a flue gas residence time of over 2 seconds. Auxiliary combustion systems are sometimes added to maintain a temperature above 900°C, ensuring complete combustion of the mixed gases. The resulting high-temperature gases are either passed through a waste heat boiler for energy recovery or discharged directly into the atmosphere.

### 3.3 Equipment Models

The product models are as follows:

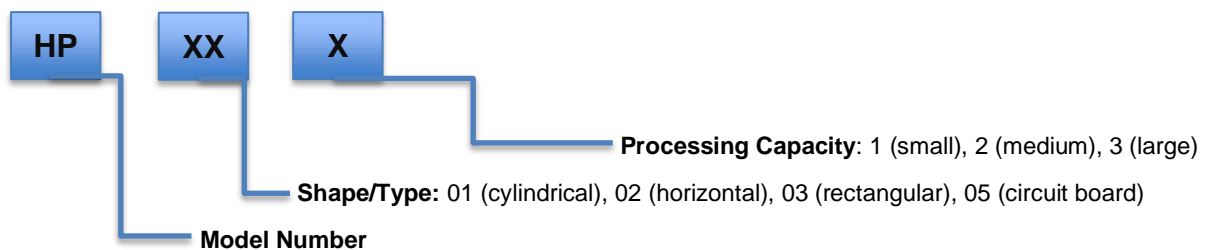

Small models have an inner diameter of  $\leq 800\text{mm}$ , medium models range from 800–1200mm, and large models have a diameter of  $\geq 1200\text{mm}$ .

The choice of furnace type significantly impacts the quality of gasification and combustion. Based on specifications, standards, and engineering requirements, three standard furnace models are available:

1. **Vertical Gasification Incinerator:**  $\Phi 920\text{-h}2000$
2. **Horizontal Gasification Incinerator:**  $\Phi 1000\text{-L}1800\text{-h}2300$
3. **Horizontal Gasification Incinerator:**  $\Phi 1200\text{-L}2700\text{-h}2600$

### 3.3.1 Horizontal Gasification Incinerator Φ1100-L1800-h2300

Main Technical Parameters:

Daily Capacity(m <sup>3</sup> )	Dimensions	Motor Power (W)	Operating Temperature (°C)		
			Oxidation layer	Reduction layer	Pyrolysis layer
10	Φ1100-L1800-h2300	370	900—1500	700—900	200—700

Table 4: Main Technical Parameters of Horizontal Gasification Incinerator Φ1100-L1800-h2300

Key Supporting Equipment:

Equipment Name	Quantity	Specifications and Parameters
Fan	2	Power: 120–250W
Gas Stove	1	Inner Φ500-h1000
Feeding System	1 set	Push device
Ash Discharge Device	1 set	Ash box
Auxiliary Furnace	1 set	Inner Φ270-h300
Cyclone Dust Collector	2 sets	Φ300-h1500

Table 5: Supporting Equipment for Horizontal Gasification Incinerator Φ1100-L1800-h2300

### 3.3.2 Horizontal Gasification Incinerator Φ1200-L2700-h2600

Main Technical Parameters:

Daily Capacity(m <sup>3</sup> )	Dimensions	Motor Power (W)	Operating Temperature (°C)		
			Oxidation layer	Reduction layer	Pyrolysis layer
10	Φ1200-L2700-h2600	520	900—1500	700—900	200—700

Table 6: Main Technical Parameters of Horizontal Gasification Incinerator Φ1200-L2700-h2600

Key Supporting Equipment:

Equipment Name	Quantity	Specifications and Parameters
Fan	2	Power: 150–370W
Gas Stove	1	Inner Φ600-h1100
Feeding System	1 set	Push device
Ash Discharge Device	1 set	Ash box
Auxiliary Furnace	1 set	Inner Φ270-h300
Cyclone Dust Collector	2 sets	Φ300-h1500

Table 7: Supporting Equipment for Horizontal Gasification Incinerator Φ1200-L2700-h2600

### 3.3.3 Vertical Rectangular Gasification Incinerator HP031

#### 3.3.3.1 Overview

Main Technical Parameters:

Daily Capacity(m <sup>3</sup> )	Dimensions	Motor Power (W)	Operating Temperature (°C)		
			Oxidation layer	Reduction layer	Pyrolysis layer
3	L1400-W1420-H1780	250	900—1500	700—900	200—700

Table 8: Main Technical Parameters of Vertical Gasification Incinerator Φ920-h2000

#### 3.3.3.2 Appearance Front View

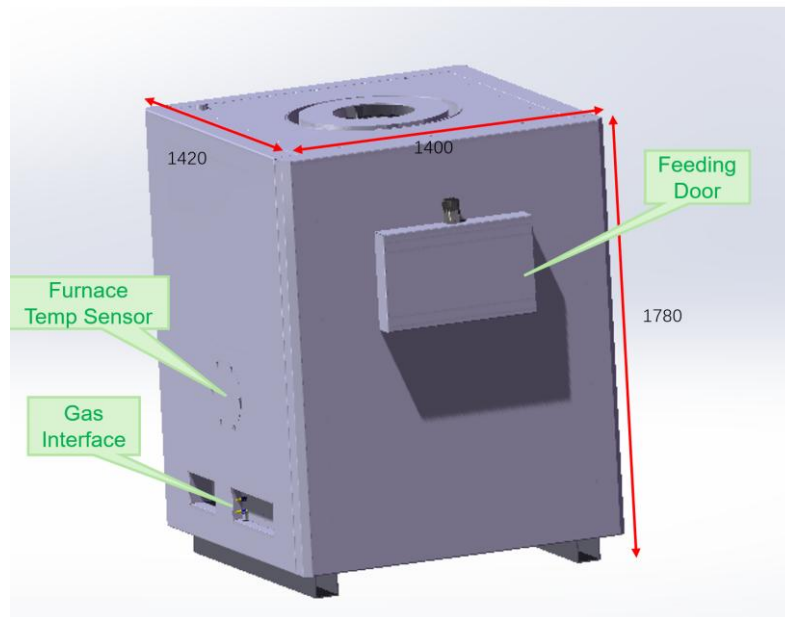

#### 3.3.3.3 Appearance Back View

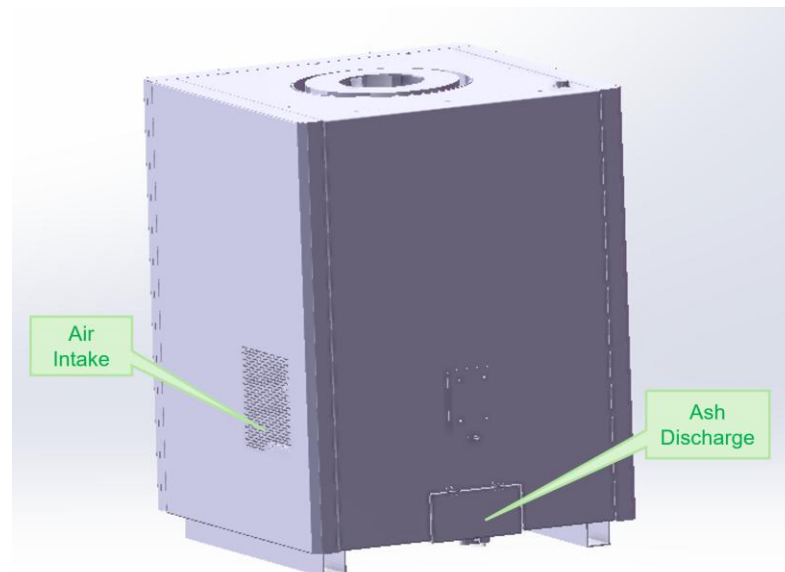

### 3.3.3.4 Interior Front View

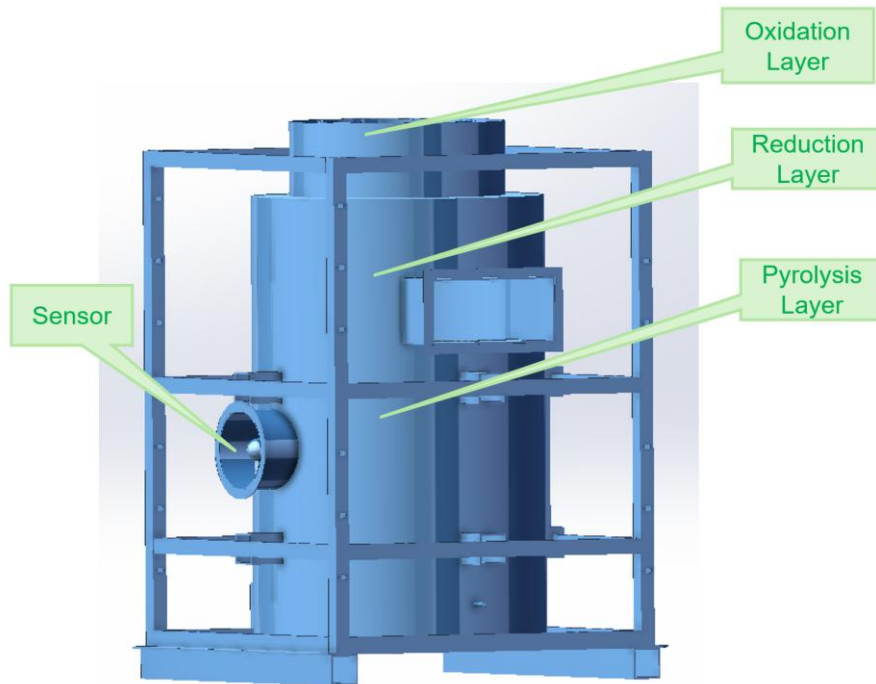

### 3.3.3.5 Interior Back View

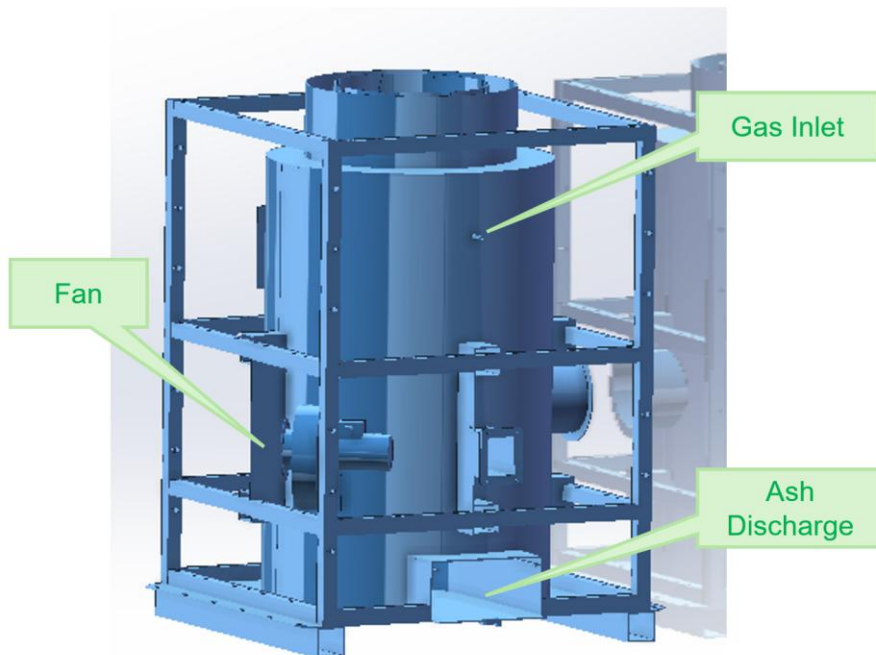

## 3.4 Manufacturing

### 3.4.1 Material Specifications

- The materials used for manufacturing must meet the requirements of the design documents and include quality certificates.

- The steel plates for the furnace body should comply with the provisions of **GB 713**, refractory materials for the furnace chamber should comply with **DL/T 902**, and the grate material should comply with **GB/T 9437**.
- Pipes should comply with **GB/T 8163**, and welding rods should comply with **GB/T 5117**.

### 3.4.2 Processing and Welding Techniques

- All component welding must comply with the provisions of **GB/T 985.1** and meet the specified process requirements.
- The refractory material lining of the furnace chamber should comply with the provisions of **GB 50211**.
- Deviations in interfaces, displacement, and flange inclination should comply with **GB/T 985.1**.

## 3.5 Components

### 3.5.1 Feeding System

- The feeding system should match the gasifier and accommodate different raw material types and feeding quantities.
- After installation, the system should operate flexibly and smoothly without jamming.
- The components of the feeding system must meet the design document requirements in terms of manufacture, installation, and material quality.

### 3.5.2 Furnace Body

Part Name	Design Temperature (°C)	Steel Grade	Quality Standard	Main Weld Type
Inner Tube	1100	20g	GB 713	Double-sided Weld
Outer Tube	600	Q235A	GB/T 3274	No restriction

Table 2: Furnace Body Design Parameters

### 3.5.3 Grate

- The grate structure should facilitate the discharge of ash and slag and ensure uniform distribution of gasification agents, supporting stable gasification of the materials inside the furnace.
- Grate casting materials should comply with design document requirements, have no cracks, smooth surfaces, and meet the quality requirements of GB/T 9437.
- The manufacturing process must meet the standards and design document requirements, as well as the provisions of JB/T 5000.

- The ash discharge door material must comply with GB 713 and ensure good sealing performance.

## 4. Inspection and Testing Methods

### 4.1 Visual Inspection

The furnace body, grate, and feeding system are inspected visually to meet the technical requirements specified in Section 5.1.

### 4.2 Airtightness Testing

After welding the inner layer of the gasifier, airtightness testing must be conducted in accordance with **NY/T 433**.

### 4.3 Performance and Gas Indicators Testing

Performance and gas quality tests for the gasifier are conducted based on the items and methods outlined in **Table 3** below.

No.	Test Item	Test Method
1	Gasification Efficiency	As per NT/Y 1017
2	Rated Gas Output	As per NT/Y 1017
3	Gas Low Heat Value	As per NT/Y 1017
4	Tar and Dust Content	As per GB/Y 12208
5	Oxygen (O <sub>2</sub> ) Content	As per NT/Y 1017
6	Carbon Monoxide (CO) Content	As per NT/Y 1017
7	Hydrogen Sulfide (H <sub>2</sub> S) Content	As per NT/Y 1017

**Table 3: Gasifier Performance and Gas Indicator Testing**

## 5. Waste Gasification Process

### 5.1 Solid Waste Treatment Process

- Solid waste is placed into a sealed container and transported to the treatment site by specialized vehicles. It is then fed into the gasifier through the loading port and passes through the furnace chamber in stages: drying, pyrolysis, reduction, oxidation, and cooling, before discharging ash and slag.
- Combustible gas produced by gasification enters the gas stove, where it undergoes secondary combustion with additional air (oxygen-rich) or auxiliary fuel. The gas temperature is maintained above 900°C for more than 2 seconds. Exhaust gases are sent through heat recovery boilers for energy utilization, followed by a cyclone dust collector to remove potential hazardous waste and particulates, before being vented to the atmosphere.

- Bottom ash, consisting entirely of inorganic materials, is solidified and either landfilled or used as construction material.

Process Flow Diagram for Waste Gasification is as follows:

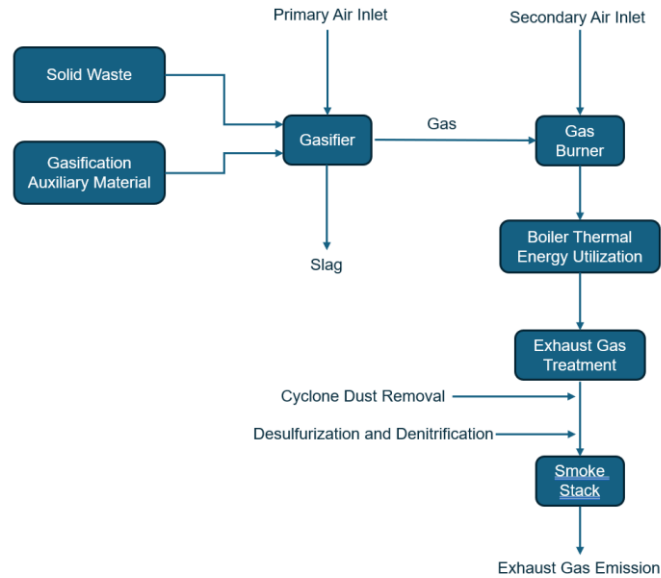

Figure 2 Waste Gasification and Incineration Process Flow Diagram

## 5.2 Operational Indicators

- The gasifier should reach stable working conditions within 15 minutes of startup, with no visible black smoke during startup.
- After processing the waste, the gasifier should be fully enclosed and left to rest for 1 hour before clearing ash and inspecting the stove for readiness before the next loading.
- If operational faults occur, repairs should be completed promptly, with downtime not exceeding 10 minutes.
- Total downtime due to faults must not exceed 24 hours within the operational period, excluding time awaiting loading.
- Operational records must be maintained.

## 5.3 Exhaust Emission Standards

Exhaust emissions after gasification must comply with **GB18485-2014** limits specified in Table 10.

Pollutant Name	Emission Limit	Measurement Time
Smoke Opacity	Ringelmann Grade I	Observation
Particulate Matter (mg/m <sup>3</sup> )	30	Hourly Average
Carbon Monoxide (CO) (mg/m <sup>3</sup> )	100	Hourly Average
Sulfur Dioxide (SO <sub>2</sub> ) (mg/m <sup>3</sup> )	100	Hourly Average
Hydrogen Fluoride (HF) (mg/m <sup>3</sup> )	4	Hourly Average
Hydrogen Chloride (HCl) (mg/m <sup>3</sup> )	60	Hourly Average
Nitrogen Oxides (NO <sub>x</sub> ) (mg/m <sup>3</sup> )	300	Hourly Average
Mercury and its Compounds (mg/m <sup>3</sup> )	0.05	Hourly Average
Thallium, Cadmium and their Compounds (mg/m <sup>3</sup> )	0.05	Hourly Average
Arsenic, Nickel and their Compounds (mg/m <sup>3</sup> )	0.5	Hourly Average
Lead and its Compounds (mg/m <sup>3</sup> )	0.5	Hourly Average
Chromium, Tin, Lead, Antimony, Copper, Manganese and their Compounds (mg/m <sup>3</sup> )	2	Hourly Average
Dioxins (ng TEQ/m <sup>3</sup> )*	0.1	Hourly Average

**Table 10: Pollutant Emission Limits**

Note 1: High-temperature waste treatment generates dioxins, which are distributed in exhaust gases, fly ash, bottom ash, and wastewater. Total dioxin emissions must be controlled. The standard specifies a total dioxin limit of 50 ng TEQ/kg per kilogram of waste processed through high-temperature treatment.

In gasification processes, potential pollutants are limited to bottom ash and exhaust gases, with no wastewater or fly ash generated. After gasification and pyrolysis:

- Dioxin content in bottom ash is approximately 0.1 ng TEQ/kg, and bottom ash accounts for about 5% of total waste weight.
- For 1 kg of waste treated via gasification and pyrolysis, about 50 g of bottom ash is produced, containing approximately 5 ng TEQ of dioxins.
- Adding potential dioxin content in exhaust gases, the total dioxin emissions per kilogram of waste treated are approximately 10 ng TEQ.

## 6. Inspection Rules

### 6.1 Classification of Inspections

Inspections are divided into factory inspections and type inspections.

### 6.2 Factory Inspection

Each product must pass factory inspection conducted by the enterprise's quality inspection department in accordance with the relevant inspection items specified in this standard. Products may only leave the factory with a quality certificate and factory inspection report.

### 6.3 Type Inspection

Type inspections include gasification efficiency, rated gas production, fuel gas indicators, and all items covered in factory inspections. Type inspections must be conducted under any of the following conditions:

- When newly developed products are put into mass production.
- When design, process, or material changes are made that may affect product performance.
- When production resumes after a production halt or transfer exceeding one year.
- When type inspections are required by national market supervision authorities.

### 6.4 Sampling Methods

Samples are randomly selected from products that have passed factory inspections. At least two units per batch must be inspected. If nonconformity is detected, repairs and reinspection are allowed. If reinspection fails, the entire batch is considered nonconforming, and production may only continue after defects are resolved and the product passes inspection.

### 6.5 Inspection Items and Methods

Refer to Table 11.

No.	Inspection Item	Test Method	Factory Inspection	Type Inspection
1	Furnace appearance	6.1	+	+
2	Grate and feeding device	6.1	+	+
3	Furnace door, observation port	6.1	+	+
4	Furnace inner layer pressure test	6.2	+	+
5	Gasification efficiency	6.3	-	+
6	Rated gas production	6.3	-	+
7	Low calorific value of gas	6.3	-	+
8	Tar and dust content	6.3	-	+
9	Oxygen (O <sub>2</sub> ) content	6.3	-	+
10	Carbon monoxide (CO) content	6.3	-	+
11	Hydrogen sulfide (H <sub>2</sub> S) content	6.3	-	+

**Table 11: Factory Inspection and Type Inspection Items and Methods**

## 7. Marking, Documentation, and Transportation

### 7.1 Labeling

A label must be securely attached to the gasifier with clear inscriptions including product name, model, parameters, serial number, manufacturing date, manufacturer, and standard number.

### 7.2 Documentation

Accompanying documents should include:

- Quality certificate
- User manual
- Electrical wiring diagrams
- System connection diagrams
- Operating and maintenance manual
- Equipment list
- Factory test report

### 7.3 Storage and Transportation

- Gasifiers must be stored upright in dry, rainproof conditions.
- During transport, precautions should be taken to prevent impact and moisture exposure.

## 8. Warranty Period

The product warranty covers 18 months from the shipment date or 12 months from the start of operation, whichever comes first. The manufacturer is responsible for repairs in case of quality issues preventing normal operation.